

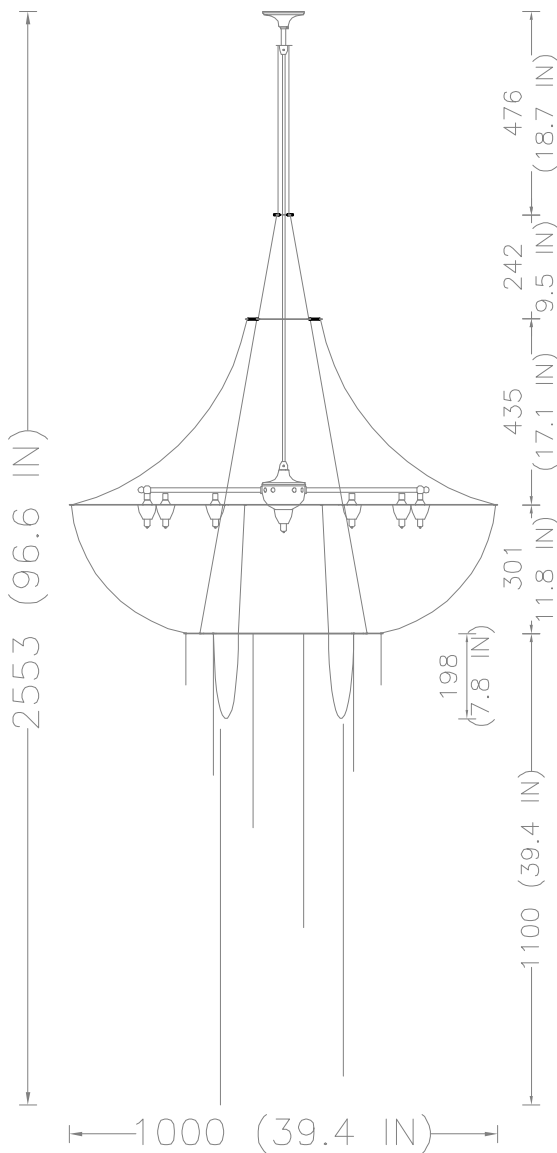

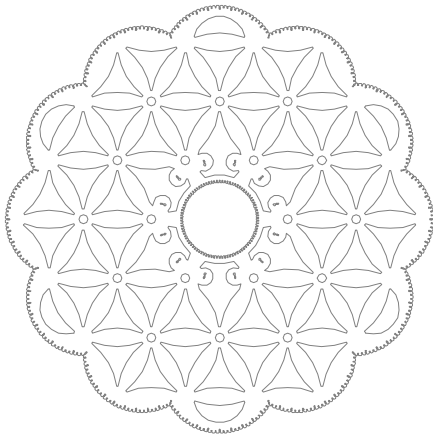

# FLOWER OF LIFE CHANDELIER 1000 willowlamp

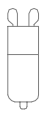

## SPECIFICATION

**FOLC RANGE** (1000mm diameter)  
**MODEL** (FOLC 1000)

*Description* Chandelier made with stainless steel frames, chrome plated brass components, ballchain (see options chart) and 19 fixed Halogen G9 lamps.

Assembly Code	Multiple fixed G9 Chandeliers
Class	I
*IP Rating (Protection rating)	20
*QC Rating (Quality rating)	21
Lamp Type & No	19x25W G9 G9 Halogen 475W 
Voltage Range	110~220V
Weight (packed weight)	20 kg. 24 kg.
Packaging Dimensions	1080x1080 x 230mm
Chain Colour & Type Options	 Silver Brass Smoke Rust White Red Black
Product Marks	 

\* See Appendix